

FOREWORD

This document, NIJ Standard-0105.01, Crash Helmets, is an equipment standard developed by the Law Enforcement Standards Laboratory of the National Bureau of Standards. It is produced as part of the Technology Assessment Program of the National Institute of Justice. A brief description of the program appears on the inside front cover.

This standard is a technical document that specifies performance and other requirements equipment should meet to satisfy the needs of criminal justice agencies for high quality service. Purchasers can use the test methods described in this standard themselves to determine whether a particular piece of equipment meets the essential requirements, or they may have the tests conducted on their behalf by a qualified testing laboratory. Procurement officials may also refer to this standard in their purchasing documents and require that equipment offered for purchase meet the requirements. Compliance with the requirements of the standard may be attested to by an independent laboratory or guaranteed by the vendor.

Because this NIJ standard is designed as a procurement aid, it is necessarily highly technical. For those who seek general guidance concerning the selection and application of law enforcement equipment, user guides have also been published. The guides explain in nontechnical language how to select equipment capable of the performance required by an agency.

NIJ standards are subjected to continuing review. Technical comments and recommended revisions are welcome. Please send suggestions to the Program Manager for Standards, National Institute of Justice, U.S. Department of Justice, Washington, DC 20531.

Before citing this or any other NIJ standard in a contract document, users should verify that the most recent edition of the standard is used. Write to: Chief, Law Enforcement Standards Laboratory, National Bureau of Standards, Washington, DC 20234.

Lester D. Shubin
Program Manager for Standards
National Institute of Justice

NIJ STANDARD FOR CRASH HELMETS

CONTENTS

	Page
Foreword.....	iii
1. Purpose.....	1
2. Scope and Classification	1
3. Definitions.....	1
4. Requirements	2
4.1 Sampling for Test	2
4.2 User Information.....	2
4.3 Labeling.....	2
4.4 Construction.....	2
4.5 Peripheral Vision	3
4.6 Impact Attenuation.....	3
4.7 Penetration Resistance.....	3
4.8 Retention System	3
5. Test Methods	3
5.1 Pretest Inspection	3
5.2 Test Sequence	3
5.3 Peripheral Vision Test.....	3
5.3.1 Test Headform.....	3
5.3.2 Test Procedure	3
5.4 Impact Attenuation Test	4
5.4.1 Test Equipment	4
5.4.2 Conditioning for Testing	5
5.4.3 Test Procedure	6
5.5 Penetration Resistance Test	7
5.5.1 Test Equipment	7
5.5.2 Test Procedure	7
5.6 Retention System Test	8
5.6.1 Test Headform.....	8
5.6.2 Test Procedure	8
Appendix A—References.....	10

NIJ STANDARD FOR CRASH HELMETS

1. PURPOSE

The purpose of this standard is to establish requirements and methods of test for helmets to be worn by drivers and passengers of surface vehicles. This standard is a revision of and supersedes NILECJ-STD-0105.00 dated June 1975. This revision of the standard changes the impact attenuation requirements, deletes the requirement for wet testing of helmets, modifies the requirement and test method for peripheral vision limits, and clarifies test methods and test equipment requirements.

2. SCOPE AND CLASSIFICATION

The scope of this standard is limited to crash helmets which are of a single class. Ballistic helmets and riot helmets and face shields are covered by other NIJ standards [1,2].*

3. DEFINITIONS

3.1 Basic Plane

The plane through the centers of the external ear openings and the lower edges of the eye sockets (see fig. 1).

3.2 Coronal Plane

The plane, perpendicular to the basic and midsagittal planes, which passes through the centers of the external ear openings (see fig. 1).

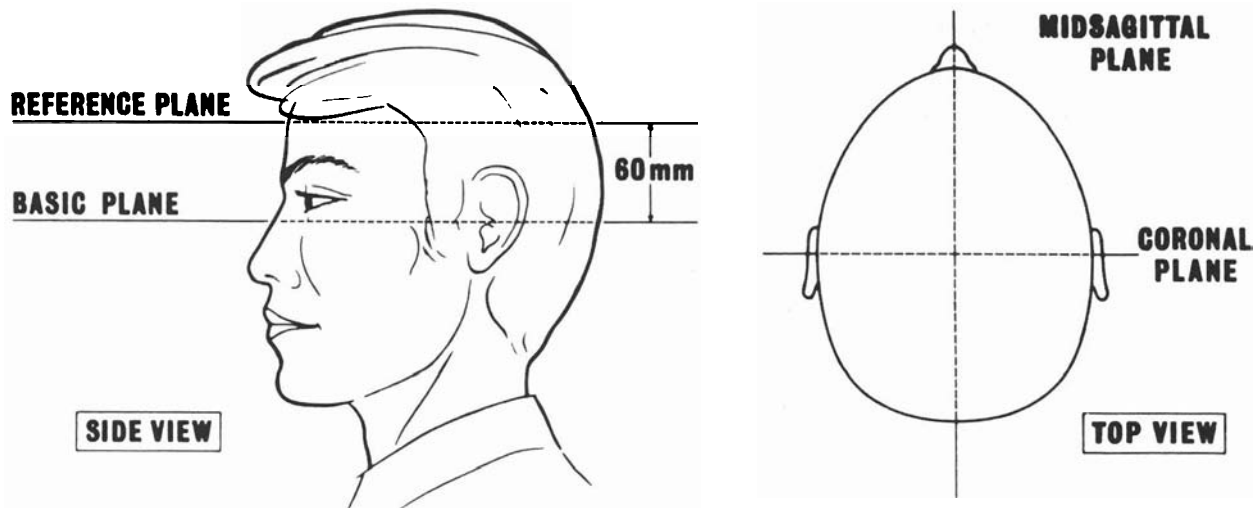

FIGURE 1. Head planes.

*Numbers in brackets refer to the references in appendix A

3.3 Edging

The edge, rim, or rim trim around a helmet.

3.4 Headform

A test device that simulates the configuration of the human head.

3.5 Impact Attenuation

A measure of the extent to which the impact energy delivered to a helmeted head is reduced by the helmet intervention. For the purpose of this standard, impact attenuation is evaluated through the measurement of the peak acceleration of a headform secured within a helmet when subjected to an impact energy of 108 J (80 lbf-ft) at a velocity of 6.6 m/s (21.7 ft/s). The peak acceleration of the headform decreases with increasing impact attenuation.

3.6 Midsagittal Plane

The plane, perpendicular to the basic and coronal planes, which symmetrically bisects the head (see fig. 1).

3.7 Reference Plane

The plane 60 ± 1 mm above and parallel to the basic plane.

3.8 Retention System

The complete assembly by which the helmet is retained in position on the head.

4. REQUIREMENTS

4.1 Sampling for Test

Four crash helmets, size 7-1/4 or medium and selected at random, shall constitute a test sample. Three helmets from the test sample shall be used as test specimens to determine compliance with the requirements of sections 4.5 through 4.8. The fourth helmet shall be reserved for retest if required in accordance with section 4.6.

4.2 User Information

The information supplied to the user with each helmet shall include the following: (a) recommended cleaning agents, paints, adhesives, etc., which can be applied to the helmet without damaging the shell and impairing its function; and (b) a warning that a helmet that has been subjected to a severe blow may thereafter offer decreased protection to the wearer.

4.3 Labeling

Each helmet shall be permanently and legibly labeled in a manner such that the label can be easily read without removing padding or any other permanent part, and shall include the following information: (a) name or designation of manufacturer; (b) model designation; (c) size; (d) month and year of manufacture; and (e) lot number. Items (d) and (e) may be incorporated into a single number such as a serial number.

4.4 Construction

The helmets shall be free from dents, blisters, cracks, crazing, chipped or sharp corners, and other evidence of inferior workmanship. They shall have no slits, holes, or other openings above the reference plane and shall have no incompressible projections that protrude more than 2.5 mm inside the shell or more than 5.0 mm outside the shell.

4.5 Peripheral Vision

The helmets shall provide peripheral visual clearance of at least 105° to each side of the midsagittal plane when measured in accordance with section 5.3.

4.6 Impact Attenuation

Three helmet test specimens shall be tested for impact attenuation in accordance with section 5.4, each of which has been conditioned to one of three different temperatures in accordance with section 5.4.2. A total of 24 impact tests is required for the three helmet test specimens (four impact sites at three temperatures and two impact energies).

The measured peak acceleration shall not exceed 320 times the standard acceleration of free fall ($320 g_n^*$) for any two of the required 24 impact tests and shall not exceed 300 g_n for the other 22 impact tests.

Should a single measured peak acceleration exceed 320 g_n and the helmet would otherwise comply with the above requirements, a retest is permitted. The retest shall be conducted with a new specimen and shall be at the same impact site, temperature, and impact energy. If the peak acceleration measured during retest does not exceed 320 g_n , the helmet meets the impact attenuation requirements of this standard.

4.7 Penetration Resistance

Each of the three helmet test specimens, conditioned as required in section 4.6, shall be tested for penetration resistance in accordance with section 5.5, without any demonstrable electrical contact being made between the penetration test striker and the test headform.

4.8 Retention System

Each of the helmet test specimens, conditioned as required in section 4.6, shall be tested for retention system static strength in accordance with section 5.6, without any break occurring and without any resulting slip or stretch of more than 25 mm.

5. TEST METHODS

5.1 Pretest Inspection

Inspect the user information provided with the helmets and the helmet labels to determine compliance with sections 4.2 and 4.3, respectively. Also examine the helmet construction and measure the distance that any incompressible projection protrudes inside and outside of the helmet shell to determine compliance with section 4.4, and verify that the helmets are size 7-1/4 or medium.

5.2 Test Sequence

The helmets shall be tested for compliance with the requirements of sections 4.5, 4.6, 4.7, and 4.8, in that sequence.

5.3 Peripheral Vision Test

5.3.1 Test Headform

The test headform shall be size 7-1/4 (see fig. 3). The measurement of peripheral vision is facilitated by two symmetrical slots that define a 125° angle lying in the basic plane, with the apex at the point of intersection of the midsagittal and basic planes and the front surface of the headform, as shown in figure 2.

5.3.2 Test Procedure

Place the helmet squarely on the headform so that the midsagittal plane of the helmet coincides with the midsagittal plane of the headform and fasten the chin strap securely. The angle of peripheral vision is shown in figure 2. It is measured as the angle lying in the basic plane with its apex at the surface of the

* $g_n = 9.81$ meters per second per second.

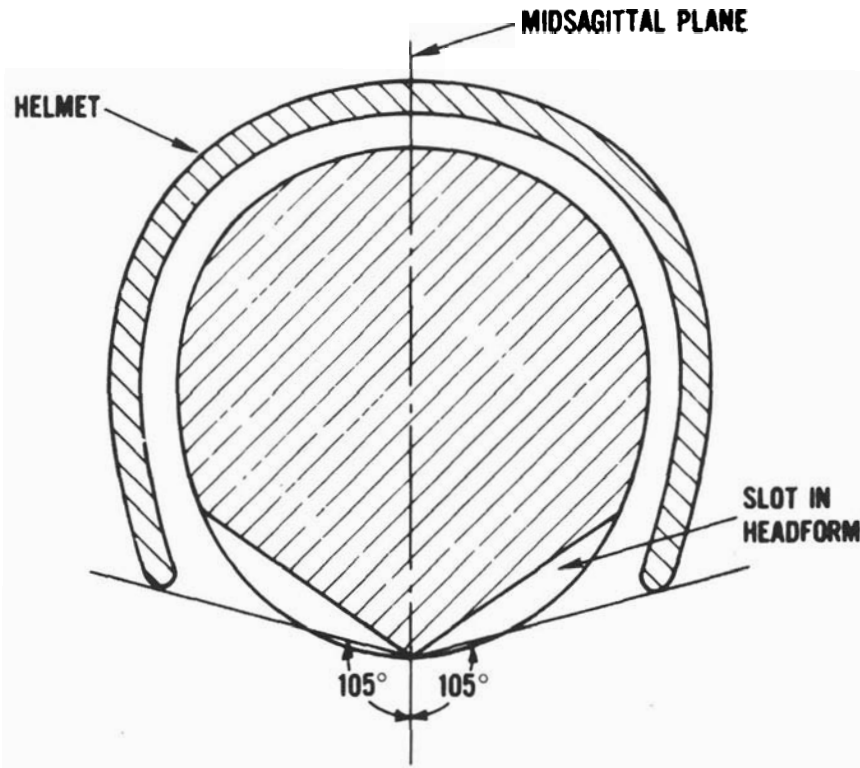

NOTE: Section through basic plane

FIGURE 2. *Peripheral vision test.*

headform, one leg tangent to the edge of the helmet, and the other the midsagittal plane. Measure the peripheral vision angle of each of the four helmet samples three times using any method accurate to 1°. Report the average of the 12 measurements as the angle of peripheral vision.

5.4 Impact Attenuation Test

5.4.1 Test Equipment

5.4.1.1 Test Headform

The test headform shall be size 7-1/4 and shall exhibit no resonance frequencies below 3000 Hz; it may be made of any nonresilient material. For the purpose of this test, nonresilient is defined as a modulus of elasticity (flexural) greater than 5×10^5 psi. Its dimensions are given in figure 3.

5.4.1.2 Drop Assembly

The drop assembly, consisting of the test headform, the accelerometer, and the supporting arm, shall have a total mass of 5.1 ± 0.1 kg. The center of mass of the assembly shall lie within a cone of 10° included angle about the vertical, with its apex at the point of impact.

5.4.1.3 Test Anvil

The test anvil shall be a steel plate $250 \times 250 \times 25$ mm minimum, backed with a solid mass of at least 140 kg.

5.4.1.4 Acceleration Measurement System

The accelerometer should be able to withstand shocks up to $2000 g_n$. The acceleration data channel, including all instrumentation which may alter the frequency content of the test data and all recording and analysis procedures, shall comply with SAE Recommended Practice J211b requirements for channel class 1000 [3]. The time duration of acceleration shall be measurable within ± 0.1 ms.

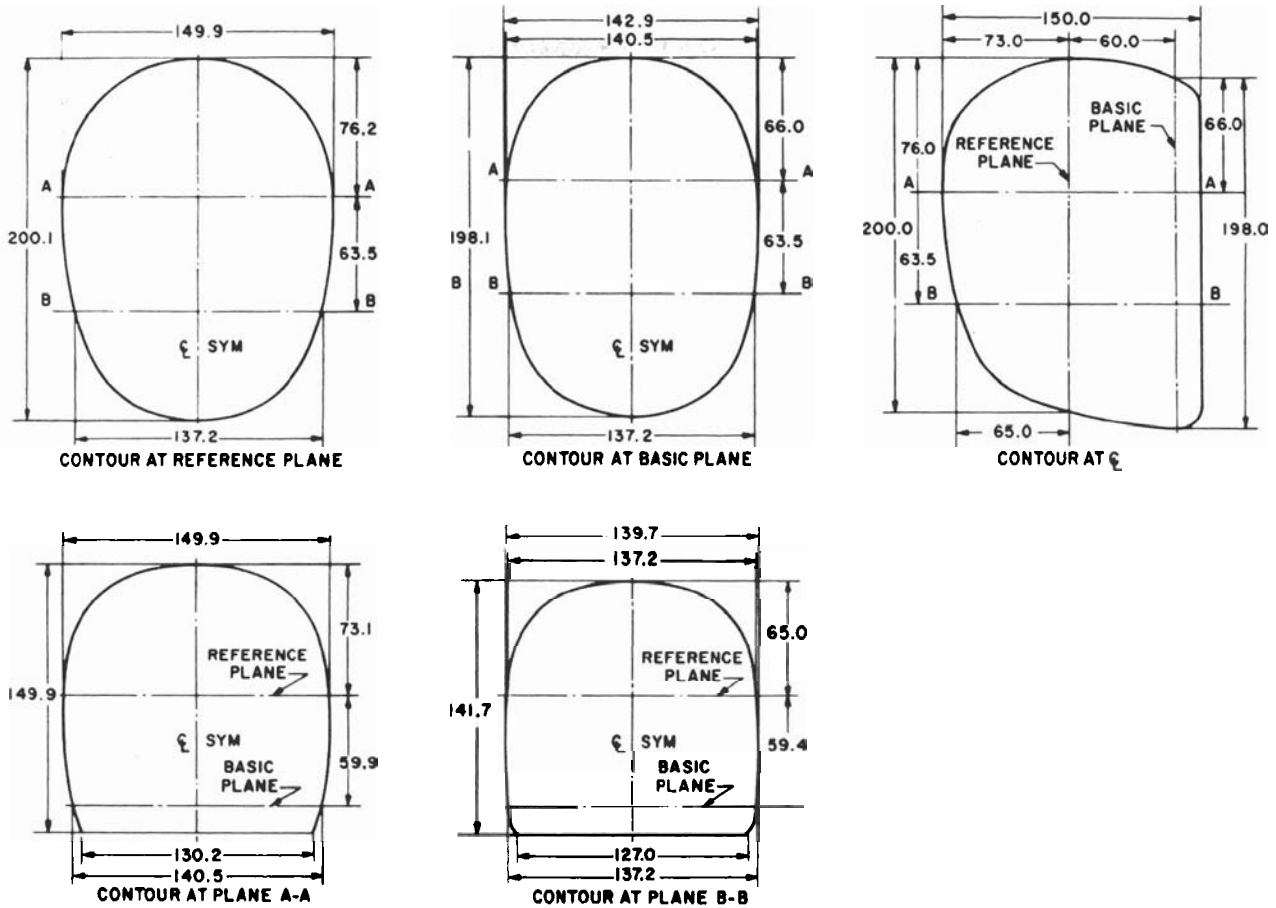

FIGURE 3. Size 7-1/4 test headform, dimensions in millimeters.

5.4.1.5 Reference Anvil

When the bare drop assembly is dropped on the reference anvil from an appropriate height, it shall produce a peak acceleration of $400 \pm 20 g_n$ and accelerations above $200 g_n$ of at least 1-ms duration. The reference anvil may be made of any material that will reproducibly yield these results with a precision of ± 0.1 ms. A reference anvil found to be suitable is a 1-in Open Blue Modular Elastomer Programmer, available from United States Testing Company, Inc., Instrument Marketing Division, 1415 Park Avenue, Hoboken, NJ 07030.

5.4.1.6 Environmental Chambers

The environmental chamber or chambers shall be capable of providing ambient temperatures of -10 ± 2 °C (14 ± 3 °F) and 50 ± 2 °C (122 ± 3 °F), and of holding those temperatures for at least 24 h.

5.4.2 Conditioning for Testing

5.4.2.1 Room Temperature

Condition one helmet at a temperature of 20 to 28 °C (68 to 82 °F) for at least 4 h.

5.4.2.2 Low Temperature

Condition a second helmet by placing it in an environmental chamber at a temperature of -10 ± 2 °C (14 ± 3 °F) for not less than 4 h nor more than 24 h.

5.4.2.3 High Temperature

Condition a third helmet by placing it in an environmental chamber at a temperature of 50 ± 2 °C (122 ± 3 °F) for not less than 4 h nor more than 24 h.

5.4.3 Test Procedure

Set up the test equipment as shown in figure 4. Mount the accelerometer at the center of mass of the drop assembly with the sensitive axis aligned to within 5° of the vertical. Throughout the calibration and testing, maintain the ambient temperature at 20 to 28 °C (68 to 82 °F) and the relative humidity at 30 to 70 percent.

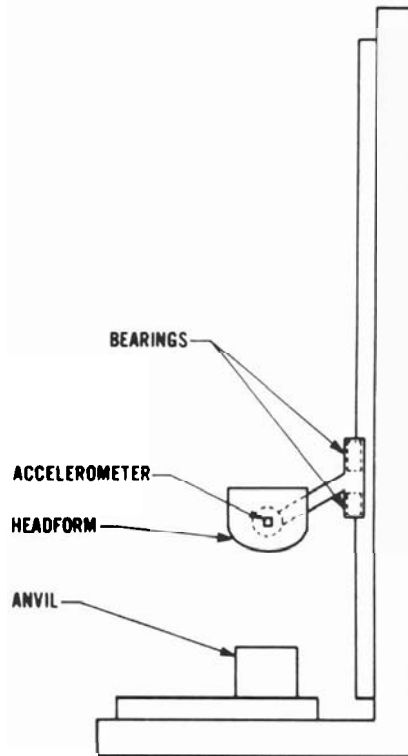

FIGURE 4. Impact attenuation test setup.

Prior to testing, allow all electronic equipment to warm up for 30 min or until stability is achieved, whichever time is greater. Check the instrumentation before and after each period of testing by dropping the bare instrumented drop assembly onto the reference anvil three times from the height which experience has shown will produce a peak acceleration of $400 \pm 20 g_n$ and an acceleration above $200 g_n$ of at least 1-ms duration. Should the average acceleration-time history obtained prior to testing differ from this, adjust the equipment as necessary. Should the post-test average differ from the pretest average by more than $40 g_n$, discard the entire test series.

Precondition one each of the three helmets comprising the test sample to room temperature, low temperature, and high temperature, in accordance with section 5.4.2. Begin testing immediately after a helmet is removed from the conditioning environment. After 5 min of testing return the helmet to the conditioning environment for at least 15 min, and continue this alternation until the testing is completed.

Position the helmet squarely on the test headform and secure it by its chin strap or other means that will not interfere with the test. Adjust the vertical drop height to provide an impact velocity of 6.6 ± 0.3 m/s and impact the helmet; then adjust the vertical drop height to provide impact velocity of 6.2 ± 0.3 m/s and impact the helmet a second time. The impact point of the second drop shall be within 25 mm of the first drop. Impact each helmet twice at each of four sites: front, side, back, and top, as follows:

Impact the front of each helmet in the area bounded by the reference plane, the plane parallel to and 50 mm above the reference plane, and the planes parallel to and 50 mm to either side of the midsagittal plane.

Impact the side of each helmet in the area bounded by the reference plane, the plane parallel to and 50 mm above the reference plane, and the planes parallel to and 50 mm to either side of the coronal plane.

Impact the back of each helmet in the area bounded by the reference plane, the plane parallel to and 50 mm above the reference plane, and the planes parallel to and 50 mm to either side of the midsagittal plane.

Impact the top of each helmet at a point within 50 mm of the intersection of the midsagittal plane, the coronal plane, and the outer surface of the helmet.

Record the acceleration-time history of each impact and continue this procedure until each of the three conditioned helmets has been tested. Following the test, inspect the data for compliance with the requirements of section 4.6. If necessary, condition the fourth helmet as appropriate and impact it once at the retest impact location.

5.5 Penetration Resistance Test

5.5.1 Test Equipment

5.5.1.1 Test Headform

The test headform shall be size 7-1/4 and, above the reference plane, shall have an electrically-conductive surface which is electrically connected to the contact indicator (sec. 5.5.1.3). While the material used for the electrically-conductive surface is not critical, aluminum foil is not suitable for this purpose.

5.5.1.2 Penetration Striker

The penetration striker shall be electrically conductive and have a mass of $3000 \pm 45 - 0$ g. The point of the striker shall be a cone with an included angle of $60 \pm 0.5^\circ$, a height of 38 mm, and a tip radius of 0.5 ± 0.1 mm. The hardness of the striking tip shall be Rockwell scale-C 60. The penetration striker shall be electrically connected to the contact indicator (sec. 5.5.1.3).

5.5.1.3 Contact Indicator

The contact indicator shall indicate when electrical contact of 1-ms duration or longer has been made between the penetration striker and the conductive surface of the test headform.

5.5.2 Test Procedure

Set up the test equipment as shown in figure 5. Again condition each of the three helmets that had been subjected to the impact attenuation test in the same environment in which it had been conditioned for that test, as described in section 5.4.2.

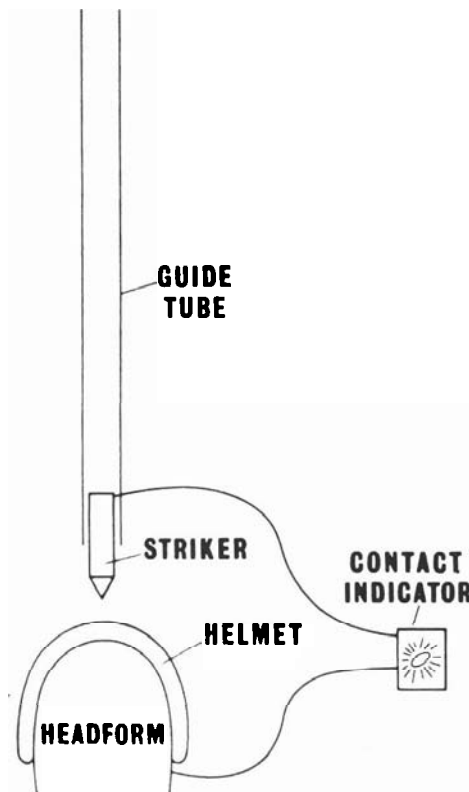

FIGURE 5. Penetration test setup.

Place the conditioned helmet on the test headform and secure it by its chin strap or by other means that will not interfere with the test. Adjust the helmet in the same manner as a person would adjust it to his or her head. Drop the penetration striker in guided fall onto the outer surface of the helmet anywhere above the reference plane and at least 75 mm from the center of a previous impact site or penetration site. Drop the striker from a height of $3.00+0.01-0$ m, as measured from the striker point to the point of the impact on the outer surface of the helmet. Subject each of the three helmets to at least two penetration blows. Following each test, remove the helmet from the headform and touch the electrically-conductive surface with the penetration striker at the point of impact to verify the continuity of contact indicator circuit.

5.6 Retention System Test

5.6.1 Test Headform

The test headform shall be size 7-1/4 and capable of supporting the helmet when a load of 1500 N (337 lbf) is applied to the retention system.

5.6.2 Test Procedure

Again condition each of the three helmets that had been subjected to the impact attenuation and penetration resistance tests in the same environment in which it had been conditioned for those tests, as described in section 5.4.2.

Place the conditioned helmet on the rigidly-mounted test headform in such a manner that it will not move during the application of the test loads and fasten the chin strap to the loading device, as shown in figure 6. Take care that the points of attachment of the chin strap to the helmet as well as the chin strap itself will be subjected to the test.

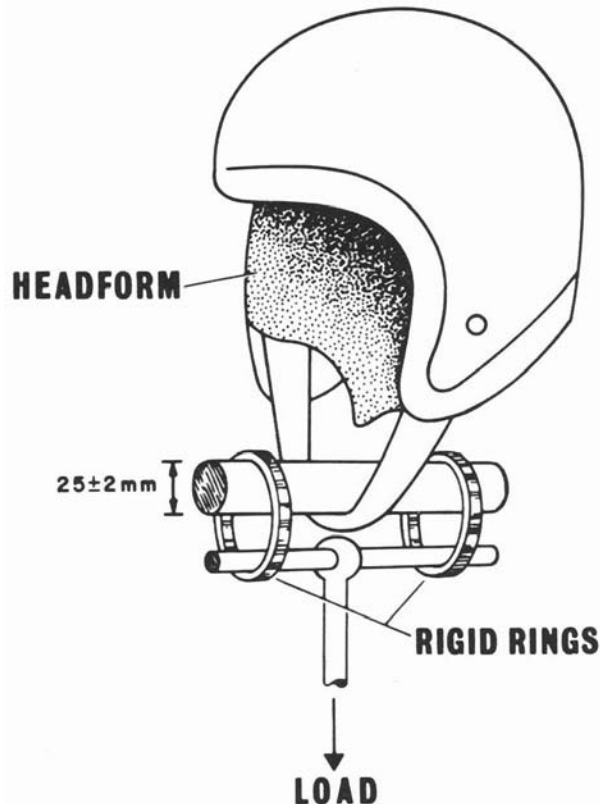

FIGURE 6. Retention system test setup.

Apply the test loads perpendicular to the basic plane of the headform and symmetrically with respect to the helmet retention system.

Statically load the retention system with 225 N (50.6 lbf) for at least 30 s and then measure the maximum distance between the chin strap and the apex of the helmet. Do not remove the load.

Apply an additional 1230 N (276.5 lbf) to the retention system for at least 3 min and again measure the maximum distance between the chin strap and the apex of the helmet.

Record any break in the retention system and the static load at the time of failure. Record any slip or stretch as the difference between the two distance measurements. Continue this test until each of the three conditioned helmets has been tested.

APPENDIX A—REFERENCES

- [1] Ballistic helmets. NIJ Standard-0106.01; 1981 December. National Institute of Justice, U.S. Department of Justice, Washington, DC 20531.
- [2] Riot helmets and face shields. NIJ Standard-0104.02. National Institute of Justice, U.S. Department of Justice, Washington, DC 20531.
- [3] SAE recommended practice for instrumentation for impact tests. SAE J211b; 1974 December. Society of Automotive Engineers, Inc., New York, NY 10001.